

# MANUAL CHOCK CLOSURE PRESSURE VESSELS

## FEATURES

- Semi quick-acting closure
- From 2 minutes to open/close, 2 to 5 minutes to lock/unlock
- Manual loading chocks replacing heavy bolting systems
- Identifiable chocks; colours and numbers ensure correct loading sequence
- Self-locking chocks; providing a sound mechanical safety feature preventing accidental removal
- Guided Closure Alignment System for larger bore vessels; robust, allows easy and safe operation
- SWL rated closure for attachment of the DUT; simultaneous load/unload of the DUT and closure
- Multiple penetrations for tooling, electrical feed-throughs and pressure control hardware
- Low maintenance requirements
- Long service life
- Vertical in orientation providing minimal shop floor footprint

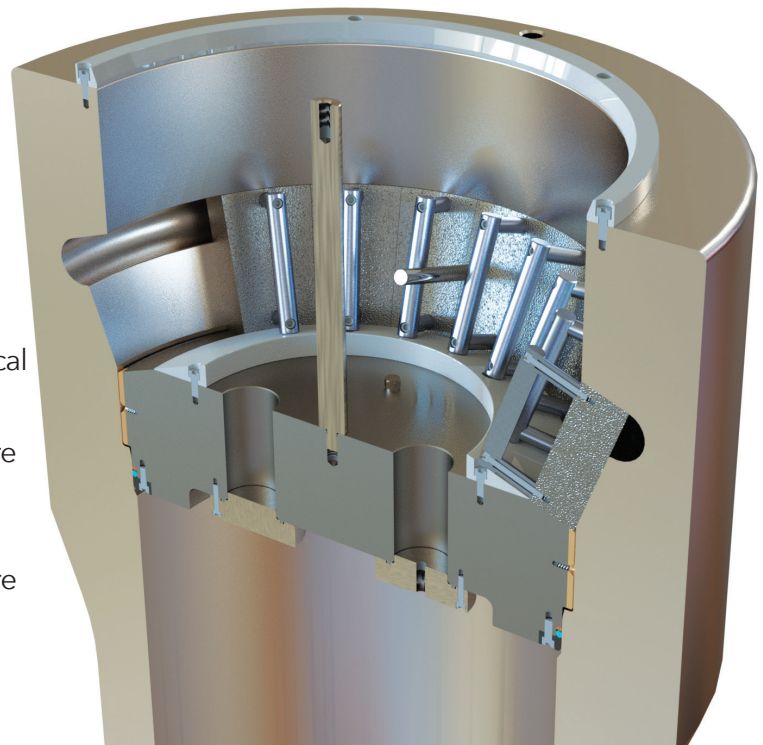

## PARAMETERS

<b>Pressure</b>	100 bar to 700 bar
<b>Temperature</b>	-20°C to 200°C
<b>Bore size</b>	Ø400mm to Ø750mm
<b>Bore depth</b>	800mm to 2500mm
<b>Volume</b>	100 litre to 1000 litre
<b>Ports</b>	1 fill/drain, 1 purge + customer specific
<b>Material of Construction</b>	Carbon or Alloy Steels
<b>Corrosion Protection</b>	Electroless Nickel Plating

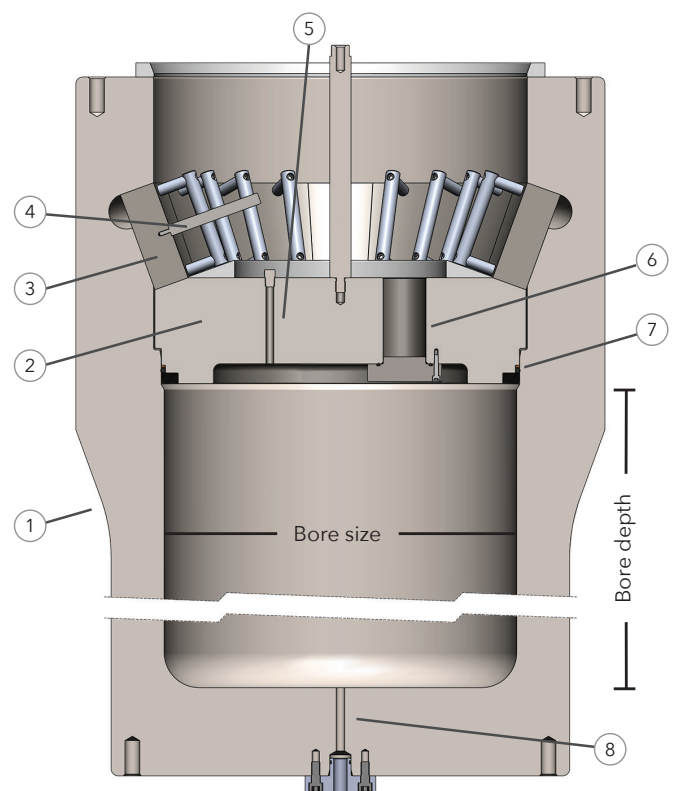

- ① Body
- ③ Chocks
- ⑤ Feed Through
- ⑦ Seal
- ② Plug
- ④ Handles
- ⑥ Tooling Port
- ⑧ Fill/Drain Port

Custom solutions are available to meet specific requirements. Please contact our engineering and technical support who will help you identify the specific options you need.